

- | ITEM | MATERIALS   |
|------|---|
| 1    | STEEL CASING.   |
| 2    | INSTALL CASING TEST STATION PER CITY STD. DWG 452.  |
| 3    | RESTRAINED JOINT CARRIER PIPE.  |
| 4    | INSTALL 60 LB. ANODE.   |
| 5    | STAINLESS STEEL CASING SPACERS WITH HEAVY-DUTY 2-INCH WIDE ANTI-FRICTION RUNNERS. MINIMUM 2 PER PIPE SECTION.   |
| 6    | GROUT FITTING PER DETAIL HEREON. INSTALL GROUT FITTINGS LONGITUDINALLY AND OFFSET 22 DEGREES FROM VERTICAL, AND ALTERNATE TO THE LEFT AND RIGHT OF THE TOP LONGITUDINAL AXIS OF THE CASING, 8-FOOT O.C. |
| 7    | 2-INCH NPT THREADED STEEL PLUG WITH RAISED HEAD.  |
| 8    | 2-INCH NPT STD. WT. STL. PIPE HALF COUPLING.  |
| 9    | BRICK AND MORTAR BULKHEADS.   |
| 10   | STEEL RAILS WELDED TO CASING INTERIOR. CONSTRUCT RAILS USING STEEL ANGLE SECTIONS AS SHOWN IN DETAIL AND AS NECESSARY TO MAINTAIN GRADE THROUGH CASING.   |

NOTES:

- INSTALL CASING BY THE BORE, JACK AND/OR TUNNEL METHOD, UNLESS DWP GENERAL MANAGER OR DESIGNEE APPROVES OPEN CUT.
- SIZE AND THICKNESS OF CASING SHALL BE AS SHOWN IN SCHEDULE. FOR LONG BORES OR SPECIAL SITUATIONS GREATER WALL THICKNESS THAN SHOWN IN SCHEDULE MAY BE REQUIRED.
- WELD FULL-CIRCUMFERENCE ALL STEEL CASING PIPE FIELD JOINTS.
- PRESSURE TEST CARRIER PIPE PRIOR TO SEALING ENDS OF CASING.
- SEAL EACH END OF CASING WITH BRICK AND MORTAR BULKHEADS.
- BACKFILL CASING IN OPEN CUT PER CITY STD. DWGS. 150 AND 406.
- PRESSURE GROUT OUTSIDE OF CASING AT GROUT FITTINGS. GROUT PRESSURE SHALL NOT EXCEED FIVE (5) PSIG (34.5KPa) FOR A DURATION SUFFICIENT TO FILL ALL VOIDS OUTSIDE OF CASING.
- INSTALLATION OF CASING BY BORE, JACK AND/OR TUNNEL METHOD REQUIRES A TUNNEL CLASSIFICATION FROM THE CALIFORNIA DIVISION OF OCCUPATIONAL SAFETY AND HEALTH, MINING AND TUNNELING UNIT.
- INSTALL AIR BLOWN SAND OR CONTROLLED LOW STRENGTH MATERIAL (CLSM) IN ANNULAR SPACE PER PLANSAND SUBJECT TO APPROVAL BY DWP. CLSM SHALL CONSIST OF CELLULAR CONCRETE WITH COMPRESSIVE STRENGTH OF 300 PSI AND 50 TO 80 PCF UNIT WEIGHT, AS MANUFACTURED BY CELL-CRETE CORPORATION, OR EQUAL.
- OPTION A - INSTALL CASING SPACERS WITH EVEN NUMBER OF RUNNERS.
- NUMBER AND PLACEMENT OF SPACERS ON CARRIER PIPE PER MANUFACTURER'S RECOMMENDATIONS, BUT NOT LESS THAN REQUIREMENTS OF THIS DETAIL.
- OPTION B - FOR HDPE PIPE, STEEL RAILS WELDED AT 5 O'CLOCK AND 7 O'CLOCK POSITIONS AT THE GRADE SHOWN ON DESIGN PLANS.

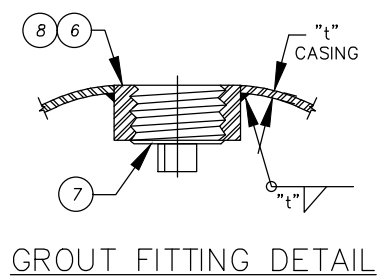
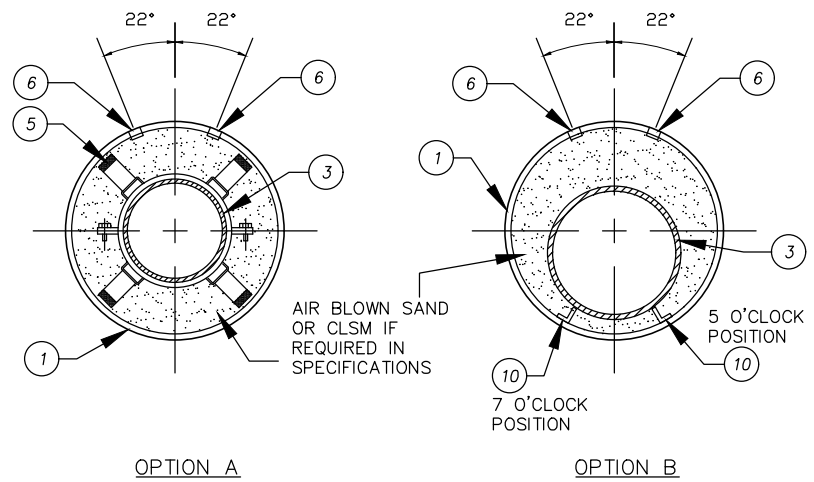

CROSS-SECTION

DIP SIZE	BELL O.D.	MIN. CASING SIZE, I.D.	MIN. WALL THICKNESS.	MIN. # OF SPACERS/ PIPE SECTION	MAX. CASING SPACERS SPACING
8"	10.8"	36"	1/2"	2	6'
10"	12.9"	36"	1/2"	2	6'
12"	15.1"	36"	1/2"	2	6'
16"	19.7"	36"	1/2"	3	4'
18"	21.9"	36"	1/2"	3	4'
20"	24.0"	36"	1/2"	3	4'
24"	28.1"	36"	1/2"	3	4'

CASING SIZE FOR CARRIER PIPE LARGER THAN 24-INCH IS SUBJECT TO APPROVAL BY DWP.

NOT TO SCALE

REVISION			APPROVED:		DATE	CITY OF CORONA
NO.	APPROVED	DATE				
1		12/28/18	Tom Koper, PE. CITY ENGINEER		10/01/20	STD 402
2	VRW	10/01/20	Vernon R. Weisman VERNON R. WEISMAN, PE. DISTRICT ENGINEER		10/01/20	
					DATE	SHEET 1 OF 1