

REMOVABLE GUARD POST

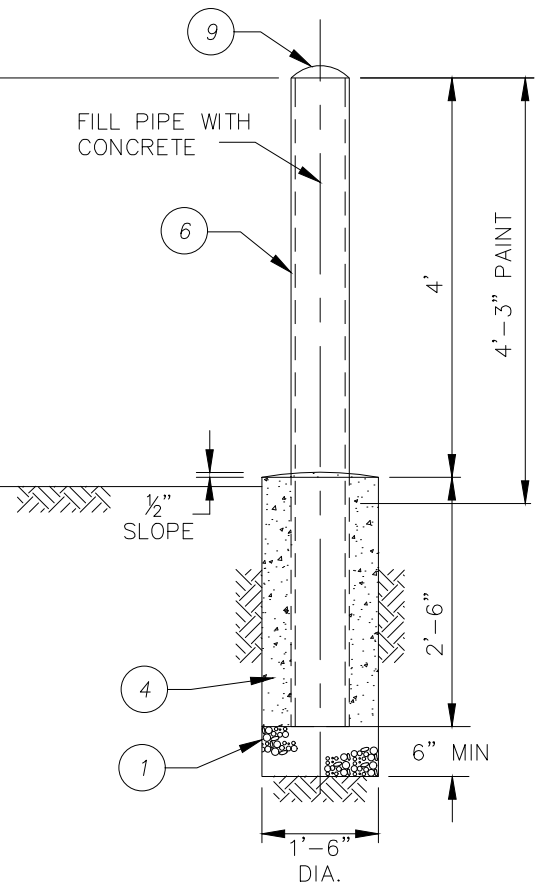

STATIONARY GUARD POST

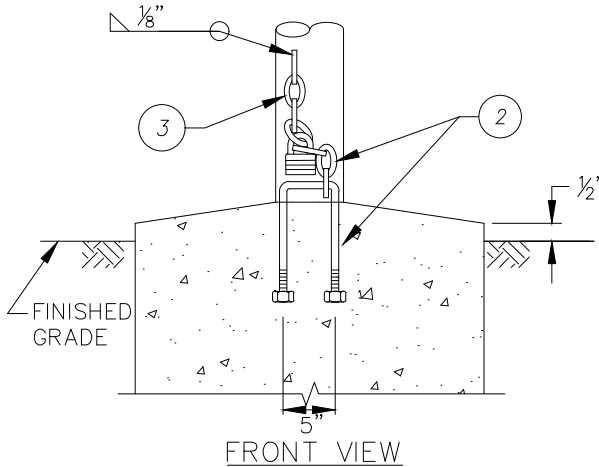

FRONT VIEW

NOTES:

1. ORIENTATE GUARD POST AS SHOWN ON PROJECT PLANS.
2. TROWEL CONCRETE POST ANCHOR SURFACE TO DRAIN AWAY FROM STEEL SLEEVE. SHAPE THE U-BOLT SWALE TO MINIMIZE THE PROTRUSION ABOVE THE ADJACENT CONCRETE TO ELIMINATE TRIPPING HAZARD.

ITEM

MATERIALS

- 1 — 3/4-INCH CRUSHED ROCK.
- 2 — EMBED 3/8-INCH DIA. 5-INCH WIDE STAINLESS STEEL U-BOLT W/NUTS INTO CONCRETE. LOOP 5 LINK STAINLESS CHAIN SEGMENT OF 3/8-INCH GRADE 80 CHAIN ONTO U-BOLT AS SHOWN IN DETAIL. SEE NOTE 2.
- 3 — 3/8-INCH DIA. GRADE 80 STAINLESS STEEL CHAIN WITH 4 1/2 LINKS. CITY TO SUPPLY LOCK.
- 4 — 560-C-3250 CONCRETE.
- 5 — FABRICATE SLEEVE FROM 8-INCH SCH. 40 STEEL PIPE. WELD STUDS AS SHOWN.
- 6 — 6-INCH DIA. SCH. 40 HOT DIP GALVANIZED STEEL PIPE, PRIME AND FINISH WITH RUST-O-LEUM SAFETY YELLOW.
- 7 — WELD 1/4-INCH PLATE CAP TO TOP AND GRIND EDGE SMOOTH.
- 8 — WELD 1/4-INCH PLATE TO BOTTOM OF SLEEVE. DRILL TWO 1/2-INCH DRAIN HOLES IN PLATE.
- 9 — ROUND OFF CONCRETE.

NOT TO SCALE

GUARD POST DETAILS

REVISION		
NO.	APPROVED	DATE
1	VRW	12/28/18

APPROVED:	
<i>Tom Koper</i>	_____
TOM G. KOPER, PE, CITY ENGINEER	
<i>Vernon R. Weisman</i>	_____
VERNON R. WEISMAN, PE, DISTRICT ENGINEER	

1/7/2019

DATE

1/7/2019

DATE



CITY OF CORONA

STD 405

SHEET 1 OF 1