

PLAN

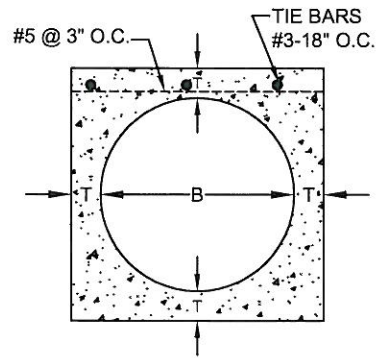

SECTION "M-M"

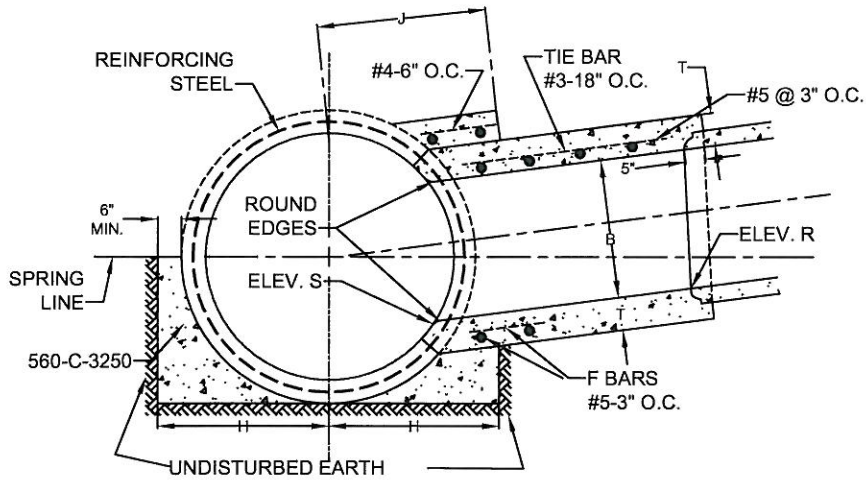

SECTION "Z-Z"

TABLE OF VALUES FOR T	
B	T
12"	5"
15"	5"
18"	5"
21"	5"
24"	5½"
27"	5½"
30"	6"
33"	6½"
36"	6½"
39"	7"

NOTE:  
A STORM DRAIN MANHOLE SHALL BE USED  
FOR ALL STORM DRAIN LINE CONNECTION  
GREATER THAN 39" DIA.



APPROVED BY:  
*Kip D. Field* 11/23/09  
CITY ENGINEER DATE  
KIP D. FIELD

CITY OF CORONA

JUNCTION STRUCTURE

REVISION	DESCRIPTION	BY	DATE

STANDARD PLAN NUMBER: **215** SHT 1 OF 2

NOTES:

JUNCTION STRUCTURE IS TO BE USED WHEN O.D. OF B IS GREATER THAN 1/2 THE I.D. OF D, OR B IS GREATER THE 24 INCHES. B SHALL NOT EXCEED 3/4 D, OR 38 INCHES. NO MORE THAN ONE OPENING SHALL BE MADE IN ONE SECTION OF PIPE.

VALUES OF A, B, C, AND D ARE SHOWN ON PROJECT DRAWINGS. ELEVATIONS "R" AND "S" ARE REQUIRED WHEN CONNECTING PIPE DOES NOT ENTER RADially.

ELEVATION "S" APPLIES AT INSIDE WALL OF STRUCTURE.

THE TRANSVERSE REINFORCEMENT IN PIPE SHALL BE CUT AT CENTER OF OPENING AND BENT INTO TOP AND BOTTOM SLABS OF SPUR.

THE MAIN LINE PIPE SHALL BE CRADLED AND ENCASED IN 560-C-3250 CONCRETE, EXTENDING LONGITUDINALLY 12 INCHES BEYOND THE LIMITS OF BREAKOUT, AND TRANSVERSELY A DISTANCE OF H ON EACH SIDE OF THE CENTERLINE OF PIPE. H=1/2 O.D. OF PIPE + 3 INCHES MINIMUM. CRADLE MAY BE OMITTED ON SIDE OPPOSITE LATERAL INLET WHEN CONSTRUCTED IN CONNECTION WITH EXISTING STORM DRAIN.

REINFORCING STEEL SHALL BE PLACED 1 1/2 INCHES CLEAR FROM FACE OF CONCRETE, UNLESS OTHERWISE SHOWN.

E AND F BARS SHALL BE CARRIED TO A POINT NO LESS THEN J DISTANCE FROM CENTERLINE. J=7/12 D + 8 INCHES.

CONCRETE STRENGTH SHALL BE 560-C-3250.

FLOOR OF STRUCTURE SHALL BE STEEL-TROWELED TO SPRING LINE.

WHEN ELEVATION "R" AND "S" ARE NOT SHOWN ON PROJECT DRAWINGS, INLET PIPE SHALL ENTER MAIN LINE RADially. WHEN INLET PIPE ENTERS MAIN LINE OTHER THAN RADially. ELEVATION "S" SHALL BE SHOWN ON PROJECT DRAWINGS, AND INLET PIPE SHALL BE LAID ON A STRAIGHT GRADE FROM ELEVATION "S" TO CATCH BASIN OR GRADE BREAK IN LINE. ELEVATION "R" SHALL BE SHOWN ON PROJECT DRAWINGS ONLY WHEN STUB IS TO BE PROVIDED IN MAIN LINE FOR FUTURE CONSTRUCTION OF INLET PIPE.

STATIONS SPECIFIED ON DRAWINGS APPLY AT THE INTERSECTION OF CENTERLINE OF MAIN LINE AND LATERALS, EXCEPT THAT STATIONS FOR CATCH BASIN CONNECTOR PIPE APPLY AT INSIDE WALL OF STRUCTURE.

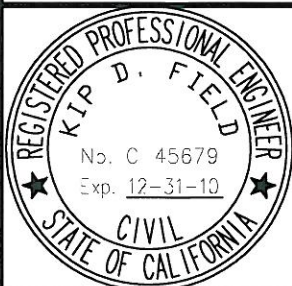

APPROVED BY:  
  
 11/23/09  
 CITY ENGINEER DATE  
 KIP D. FIELD

CITY OF CORONA

JUNCTION STRUCTURE  
 (NOTES)

REVISION	DESCRIPTION	BY	DATE

STANDARD PLAN NUMBER: **215** SHT 2 OF 2