

INSTALLATION

NOTE: GUARD RAILING FLARES AT BRIDGE APPROACHES SHALL HAVE A MINIMUM RADIUS OF 150'.

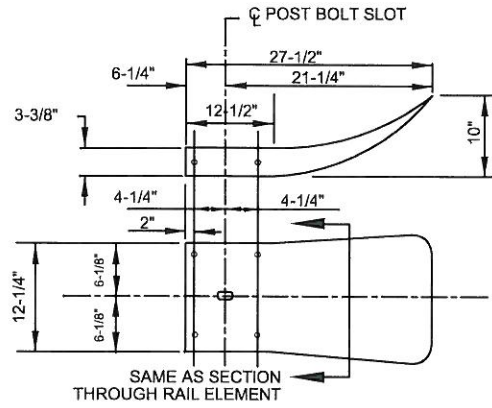

TERMINAL SECTION

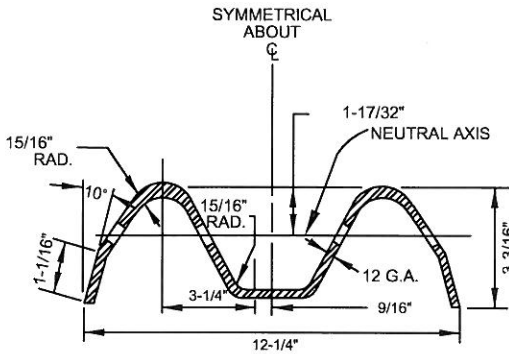

SECTION THROUGH RAIL ELEMENT

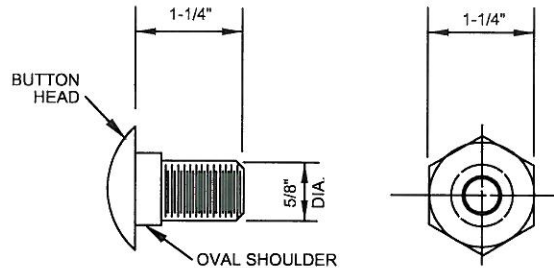

SPLICE BOLT AND NUT

POST BOLT: SIMILAR EXCEPT LENGTH

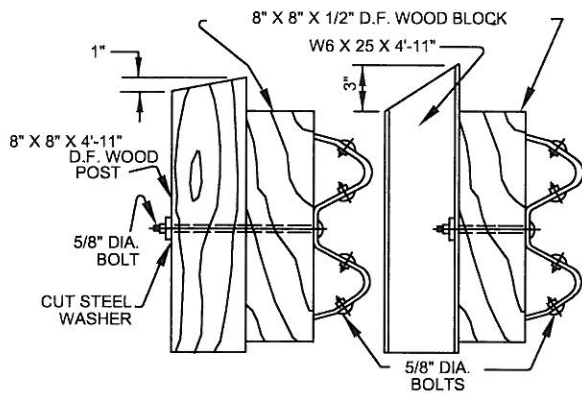

ARRANGEMENT OF POSTS

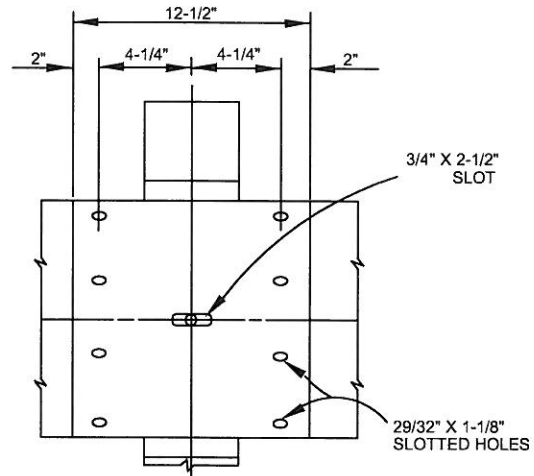

RAIL SPLICE

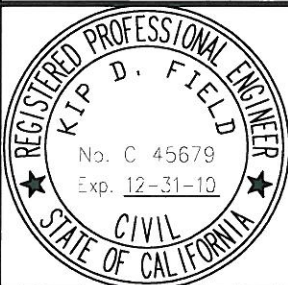

APPROVED BY: *Kip D. Field* 11/23/09
 CITY ENGINEER DATE
 KIP D. FIELD

CITY OF CORONA

METAL BEAM GUARD RAILING NOTES

REVISION	DESCRIPTION	BY	DATE

STANDARD PLAN NUMBER: **525** SHT 1 OF 1