

PAVED SHOULDER WITH AC BERM

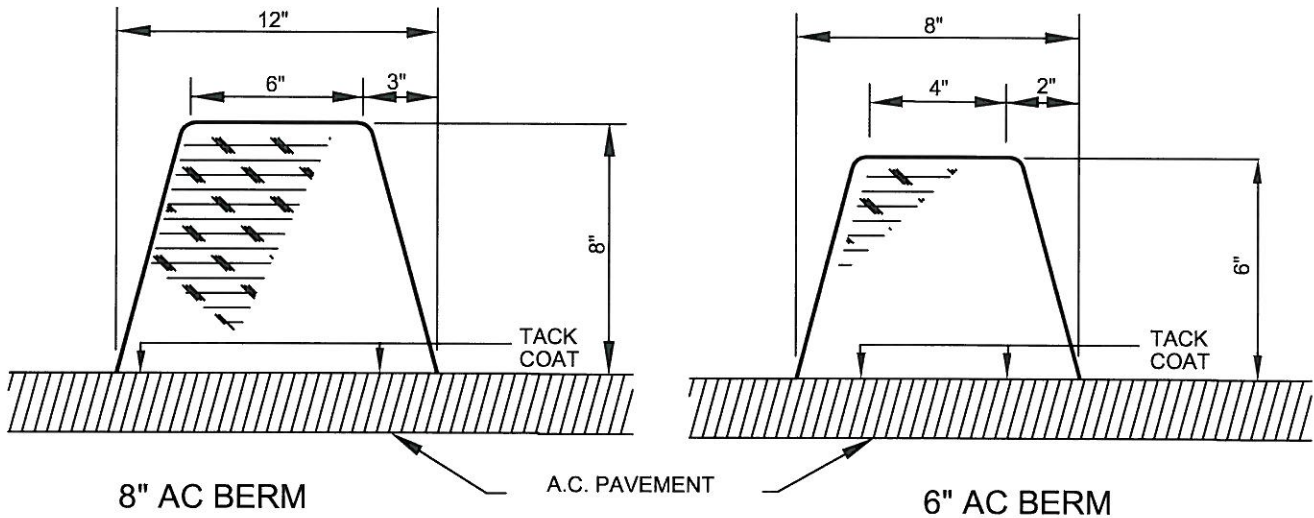

NOTES:

1. THE ASPHALT CONCRETE MIXTURE SHALL BE PG 64-10 WITH A MINIMUM ASPHALT BINDER OF 5.8 PERCENT.
2. PRIOR TO PLACEMENT, A TACK COAT SHALL BE APPLIED TO THE EXISTING SURFACE. TACK COAT SHALL BE AR1000 AT AN APPROXIMATE RATE OF 0.05 GALLON PER SQUARE YARD OR GRADE SS-1h EMULSIFIED ASPHALT AT AN APPROXIMATE RATE OF 0.05 TO 0.10 GALLON PER SQUARE YARD.
3. THE TEMPERATURE OF THE MIX AT THE TIME OF PLACEMENT SHALL NOT BE LESS THAN 250°F OR MORE THAN 285°F.
4. ALL EXTRUDERS AND SHOES SHALL BE APPROVED BY THE ENGINEER.
5. BERM TO BE PAINTED WITH WHITE STRIPED PAINT IN A 10'X10' HATCHED PATTERN. WITH REFLECTIVE BEADS.



APPROVED BY:
Kip D. Field 11/23/09
 CITY ENGINEER DATE
 KIP D. FIELD

CITY OF CORONA

ASPHALT BERM

REVISION	DESCRIPTION	BY	DATE

STANDARD PLAN NUMBER: 140 SHT 1 OF 1