

TYPICAL CROSSWALK

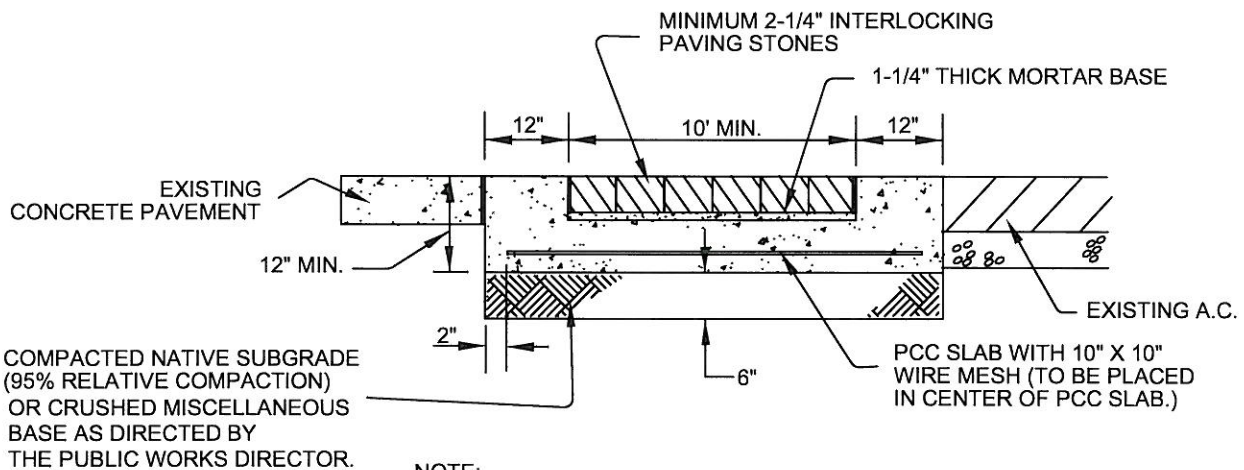

NOTE:
ALL CONCRETE SHALL BE CLASS 560-C-3250,
CURED WITH CURING COMPOUND.

SECTION "A-A"

CROSSWALK ENHANCEMENT ALLOWED ONLY WITH THE APPROVAL
OF THE PUBLIC WORKS DIRECTOR.



APPROVED BY:
KIP D. FIELD 11/23/09
CITY ENGINEER DATE
KIP D. FIELD

CITY OF CORONA

CROSSWALK
ENHANCEMENT

REVISION	DESCRIPTION	BY	DATE

STANDARD PLAN NUMBER: **148**

SHT 1 OF 1